

MTV22 & MTV02

ROUND THERMOSTATIC MIXER 2-way

meir®

MATTE BLACK
MTV22

CHROME
MTV22-C

CHAMPAGNE
MTV22-CH

TIGER
BRONZE
MTV22-BB

BRUSHED
NICKEL
MTV22-PVDBN

AVAILABLE
FINISHES



FEATURES

- 10 Year Warranty
- Flow rate 30L p/m at 3 bar.
Flow rate 17L p/m at 1 bar.
Recommended for water pressure above 0.5 bar.
- Box weight 0.95kg
- Vernet thermostatic cartridge
- Anti-scalding protection
- Temperature over-ride button
- 1-Way Fluhs diverter
- High low-pressure flow rate
- Solid Brass Construction
- Used together with the MTV02 body part.(2.3kg)

CARE

- Do not install tapware using any form of acetone silicones.
- Do not apply physical items (such as tools) directly to product.
- Never use house-hold or commercial detergents, citrus based cleaners, or abrasive cleaners.
- Clean using a mild washing soap solution rinsed, and dry with a soft cloth.
- Check for any product defects before installation.
- Refer to the installation manual for correct installation.

SPECIFICATIONS

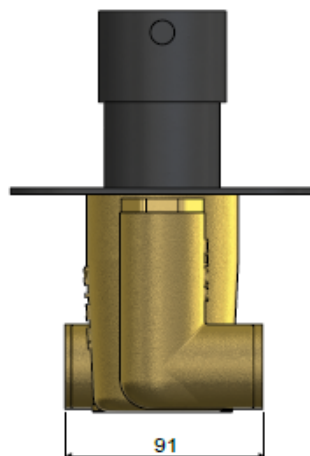
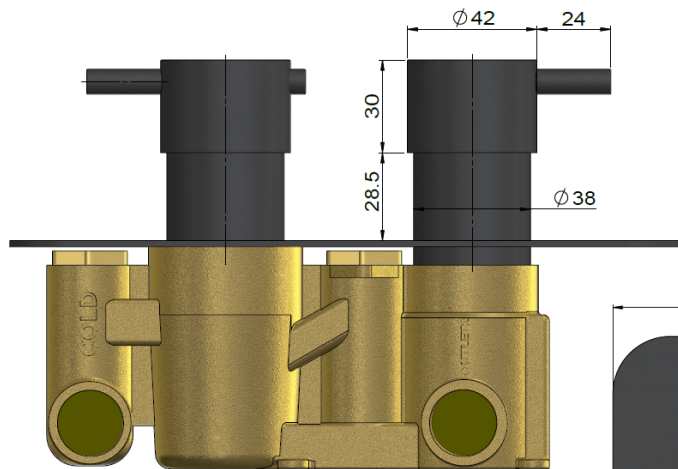
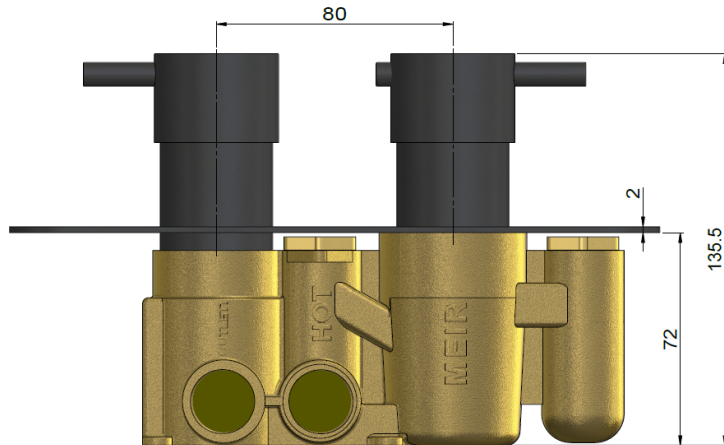

Australian installers to visit the below website before working on the thermostatic mixer valve:
<https://www.vba.vic.gov.au/plumbing/registrations-licences/thermostatic-mixing-valve>

MTV22

ROUND THERMOSTATIC MIXER 2-way

EXPLODED VIEW

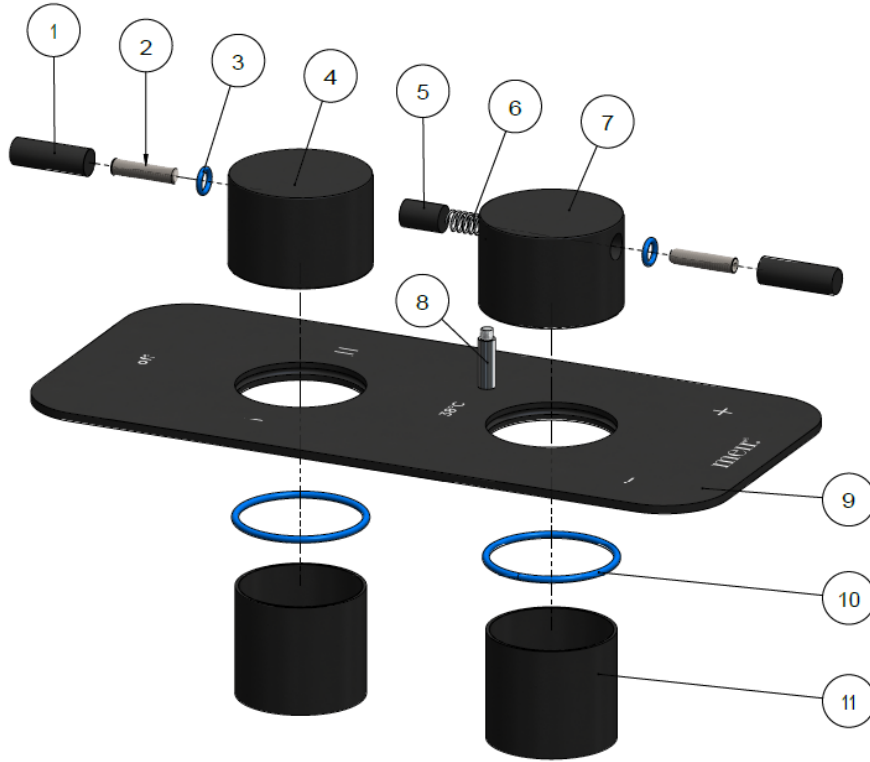

No.	Part Name
1	Pin Lever
2	Screw
3	O-ring
4	Handle
5	Button
6	Spring
7	Handle
8	Positioning Pin
9	Back Plate
10	O-ring
11	Copper Sleeve

FLOW RATE GRAPH

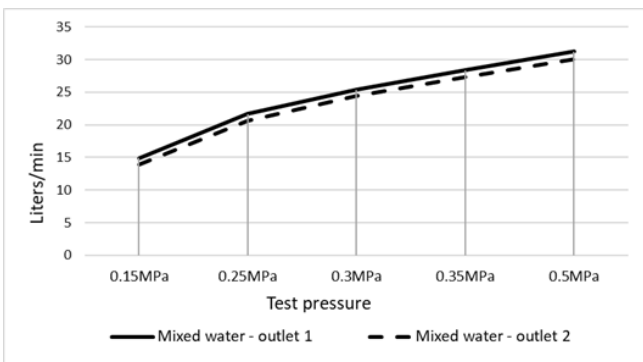

CREDENTIALS

- Applying for WRAS

TOLERANCES

