

# MW07

## DIVERTER MIXER

# meir®

MATTE BLACK  
MW07

CHROME  
MW07-C

CHAMPAGNE  
MW07-CH

TIGER  
BRONZE  
MW07-BB

### AVAILABLE FINISHES

### FEATURES

- 10 Year warranty
- In-built diverter switch
- Flow rate 18L p/m
- European components and cartridge
- Solid brass construction
- Box Weight 1.7Kg

### CARE

- Do not install tapware using any form of acetone silicones.
- Do not apply physical items (such as tools) directly to product.
- Never use house-hold or commercial detergents, citrus based cleaners, or abrasive cleaners.
- Clean using a mild washing soap solution rinsed, and dry with a soft cloth.
- Check for any product defects before installation.
- Refer to the installation manual for correct installation.

### SPECIFICATIONS

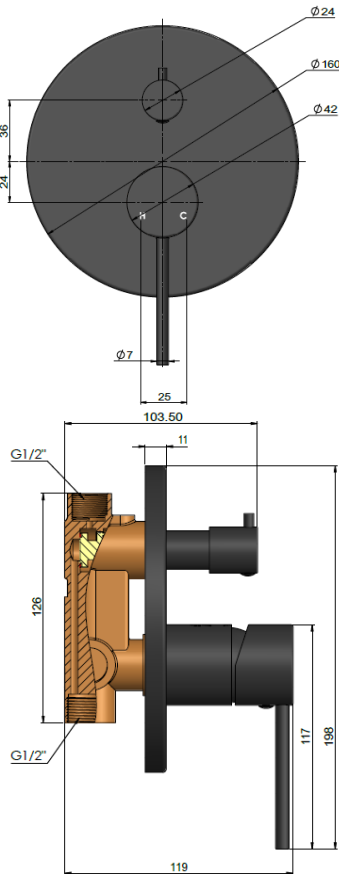

### TOLERANCES

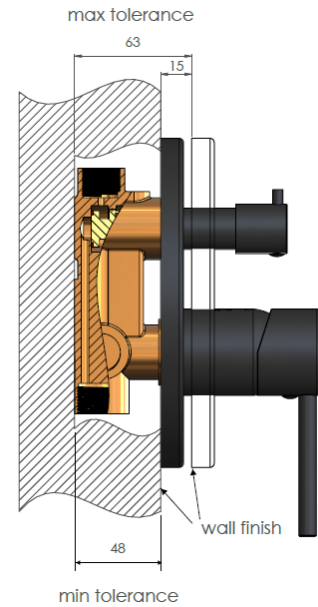

### FLOW RATE GRAPH

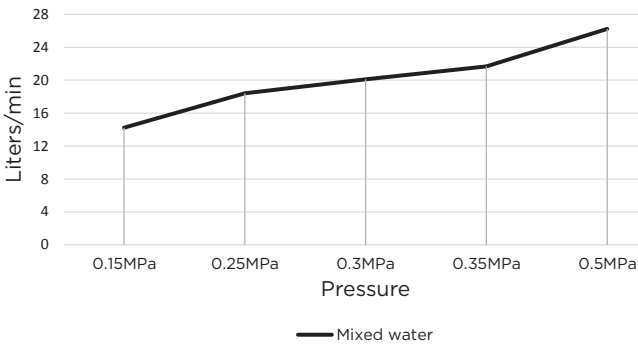

### CREDENTIALS

- Watermark AS/NZS 3718 WMKA25013

